

SensorTran DTS Information Series: Transmission & Distribution Applications

Cable Ampacity Analysis Software (CAAS)

Introduction

Fiber optic-based Distributed Temperature Sensing (DTS) systems provide real-time temperature measurements along the complete length of optical fibers. They provide a proven temperature monitoring solution for power cables. The data allows operators to maximize circuit load while avoiding over-temperature conditions, therefore increasing cable life and avoiding potential catastrophic loss of circuits.

While DTS systems alone provide excellent power cable monitoring solutions, adding ampacity analysis software increases the value of the data and offers enhanced functionality with clearly definable benefits to utility operators.

SensorTran's CAAS software suite is comprised of several modules that provide flexible, appropriate, cost-effective tools which expand the benefits of DTS systems for power cable monitoring. Labor intensive pre-modeling is kept to minimum by the use of artificial intelligence algorithms which fine-tune ampacity predictions to give greater accuracy.

Ampacity and Ratings: a brief overview

Ampacity is the current-carrying capacity of a cable.

For an underground cable, ampacity is determined by the capacity of the installation to extract cable heat and dissipate that heat into the surrounding soil and/or atmosphere.

The maximum operating temperature of a cable is typically limited by its insulation material but can also be limited by the maximum temperature which the surrounding environment can withstand without degradation.

Paul Nicholls, Executive VP, SensorTran

January 2009

The cable insulation can withstand different temperatures dependent upon duration and intensity of the current circulating in the conductors.

The consequence of operating cables at excessive temperatures is life-reducing damage to the cable or surrounding environment as typically shown below:

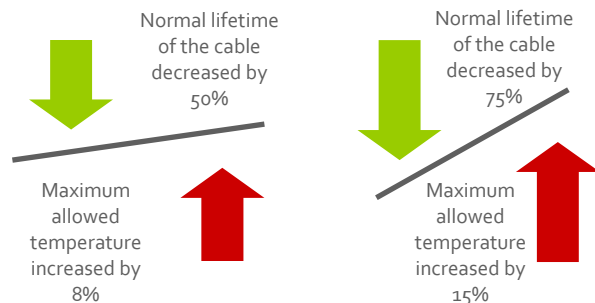

Max. Operating Temperature vs. Cable Life

Cable Temperature Ratings

Cable operating temperatures depend on the load "shape" applied (i.e. the intensity of the current and variation in current over time). Subsequently, cables have different temperature ratings for different loadings - i.e. steady state, cyclic, transient (emergency), and short-circuit.

Transient analyses are typically used to calculate cable thermal ratings under emergency situations.

Cable installations also have thermal inertia, as it takes time for the cable and its surroundings to heat up.



SENSORTRAN

Distributed Monitoring
Solutions

Power Cable Monitoring Issues

Cable Component Temperatures

DTS systems monitor the fiber temperature. It is the temperature of the conductor core (for the maximum insulation temperature) and sometimes that of the outer jacket (in cases where the surrounding environment is temperature sensitive) which should ideally be monitored.

The variation between the fiber temperature and that of the conductor core (or outer jacket) will vary depending upon the location of the fiber relative to the core (or outer jacket) and the thermal coefficients of the cable construction, as shown in the example below:

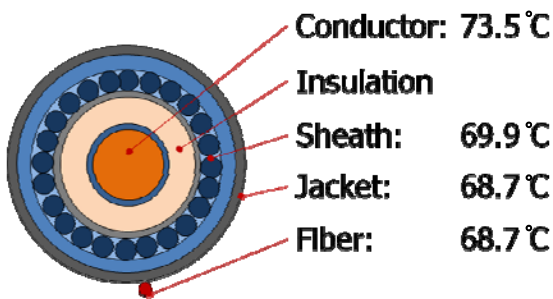

Typical Temperature Variations from the Core to the Outer Jacket

Load Temperature Latency

DTS systems provide real-time temperature data. However, there is latency between a change in the circuit load and the responding cable temperature, as shown below.

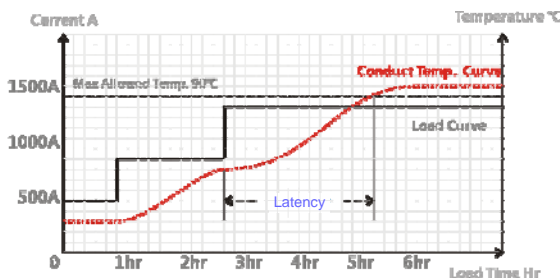

In effect, the cable’s temperature responds over time to a change in load. The shape of the cable’s responding temperature curve varies depending upon the load “shape” and the thermal characteristics of both the cable and the surrounding environment.

Benefits of Ampacity Analysis

The additional implementation of ampacity analysis software, in conjunction with DTS systems, provides the following valuable enhancements and benefits:

Cable Component Temperatures

Ampacity analysis produces real-time temperature data for multiple elements of the cable, such as the conductor core (insulation) and the outer sheath. This provides more exacting data to allow operators to maximize circuit loading while avoiding over-temperature conditions, therefore increasing cable life and avoiding potential catastrophic loss of circuits.

Cable Temperature Predictions

Ampacity analysis provides predicted cable temperatures in response to variations of the cable load. There are two elements to this, namely Static and Transient methods.

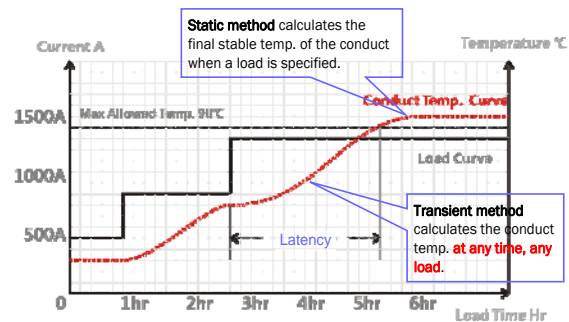

The Static method predicts the final stable cable temperature based on load condition whereas the Transient method predicts the responding cable temperature at any time to a load variation.

SensorTran’s Cable Ampacity Analysis Software (CAAS)

Introduction

SensorTran’s CAAS software suite consists of three modules as shown. Each module provides a specific function to provide configuration flexibility to ensure a cost-effective solution customized to meet exacting customer requirements.

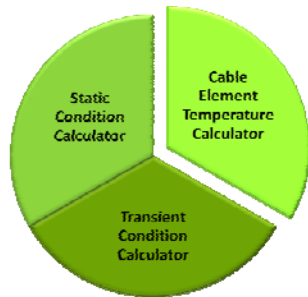

Features and Principles Overview

- Provides Cable Element, Static and Transient Condition Calculators in separate modules
- Complies with IEC guidelines for static calculations with optimized transient calculations
- On-board self-learning artificial intelligence algorithms provide fine-tuning of calculations with relatively small amounts of historical data
- Open architecture for inter-system communication
- Principles based on: Optimized IEC Standard, Neher-McGrath methods, IEC Standards 287-1-1, 287-1-2, 287-2-1, 287-2-2, 287-3-1

CAAS Modules

The table below describes the CAAS modules, required data inputs, and implementation form:

Module	Description	Data Inputs	Form
Cable Element Temperature Calculator	Provides real-time conductor core and/or outer sheath component temperatures based on fiber temperature and load	1. Fiber temperature 2. Real-time load	Software (loaded onto DTS unit)
Static Condition Calculator	Provides off-line estimate of steady-state cable temperature given the existing load	1. Real-time load 2. Load frequency and voltage (optional but provides better accuracy) 3. Fiber temperature (not required if accurate environment conditions are supplied)	Hardware Module
Transient Condition Calculator	Provides off-line query tools for estimating time-based temperature conditions based on load and durations	Same as Static Condition Calculator	Hardware Module

Cable Element Temperature Calculator

The Cable Element Temperature Calculator provides real-time conductor core and other cable element temperatures based on fiber temperature and load.

In addition to the fiber temperature and load, basic characteristics of the installed cable are required for initial modeling. This data can be superimposed on the DTS temperature trace screen typically as shown at right:

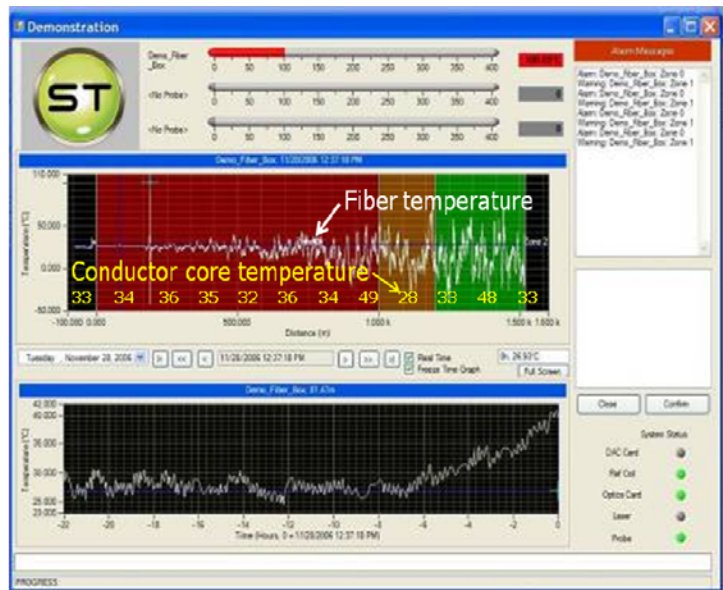

Query A:

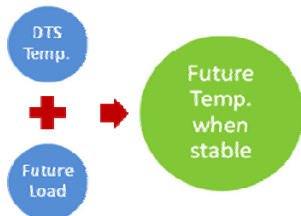

Query B:

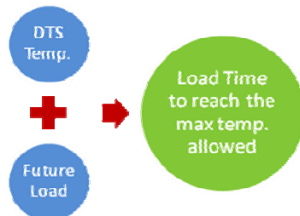

Query C:

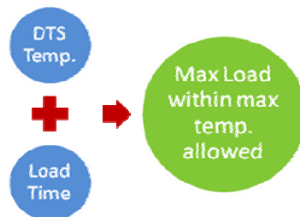

Static Condition Calculator

This module provides an off-line estimate of the predicted steady-state cable temperature with the existing load using the Static method. A simple user interface provides for the use of this tool.

Transient Condition Calculator

The Transient Condition Calculator provides off-line query tools for estimating time-based temperature conditions based on load and durations. These provide the operator with tools to determine appropriate load scenarios. Examples of these queries are shown at left.

Query inputs are entered using a simple interface. Queries can be saved and reused.

Implementation

The Cable Element Calculator module can readily reside on the integral PC within a SensorTran Gemini™ DTS system. The Static and Transient Condition Calculator modules are supplied as separate hardware units complete with their own CPU and hard-disk cache as shown at right:

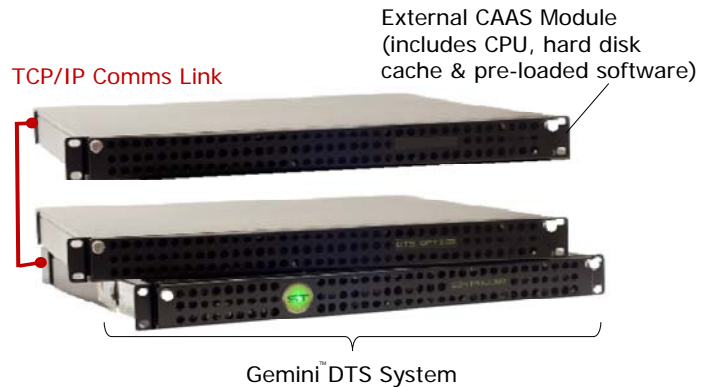

DTS\CAAS systems can be integrated within the operator’s control systems in a variety of schemes, two of which are shown below:

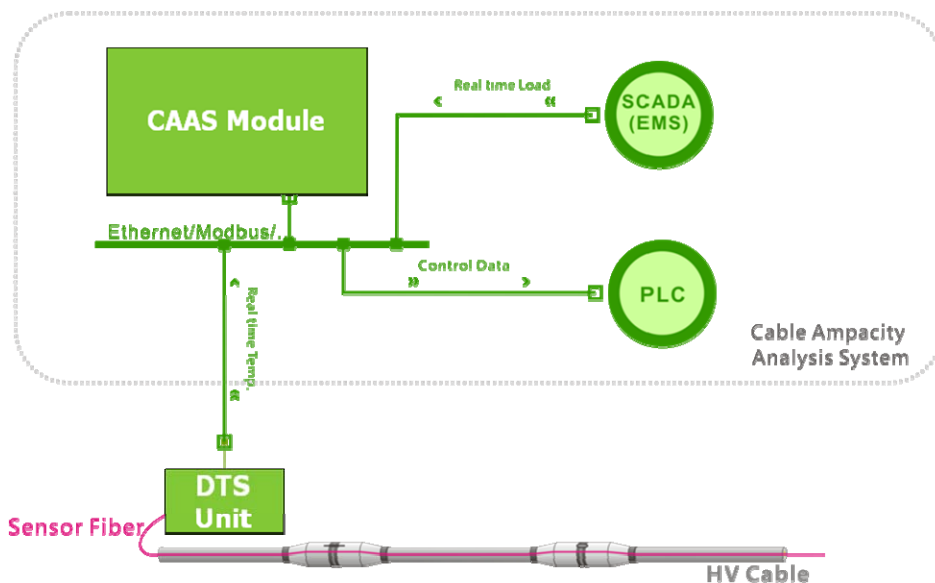
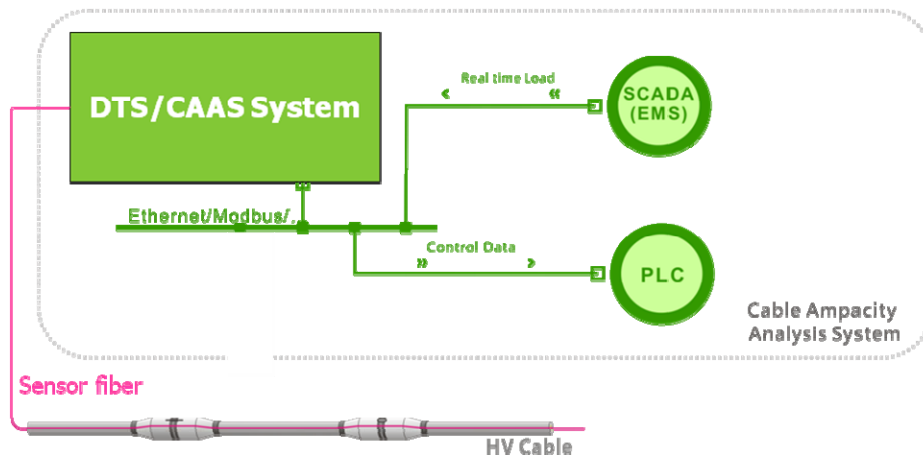

Power Cable Monitoring

SensorTran’s advanced DTS systems capture and record dense temperature measurements over time - providing operators with vital information that leads to reduced costs by increasing the usable capacity of the circuits, avoiding cable damage, and extending cable life by maintaining optimal loading. Distributed Temperature Sensing data is used for:

- Small hotspot identification
- Load optimization through real-time thermal monitoring
- Access to all usable capacity without exceeding thermal limits
- Lifetime asset protection and monitoring of aging circuits
- Verification of mathematical models
- Early identification of joint deterioration
- Fire detection capability in cable tunnels, ducts, and chases



**Underground
Transmission &
Distribution Line
Monitoring**

**Substation
Monitoring**



The SensorTran Advantage

SensorTran, a NASA technology spin-off, is committed to supplying its customers with smart distributed monitoring solutions. SensorTran’s systems are conceived to have a low lifetime cost of ownership (LCO) by way of efficient design, superior engineering and reliable construction. SensorTran’s team is dedicated to providing “best-in-industry” customer care from project conception to the development of specifications, through installation, training and beyond.



Distributed Monitoring
Solutions

Corporate HQ & Manufacturing

4401 Freidrich Lane, Bldg. 307
Austin, TX 78744
USA

+1-512-583-3520
+1-866-333-2861 (toll free domestic)

Regional Offices

Southampton, England UK
+44 1489 576648

Richmond, VA USA
+1 804-364-2645

e-mail inquiries to sales@sensortran.com

www.sensortran.com